

# CANISTER GUARD TWO PIECE KELLY VALVE

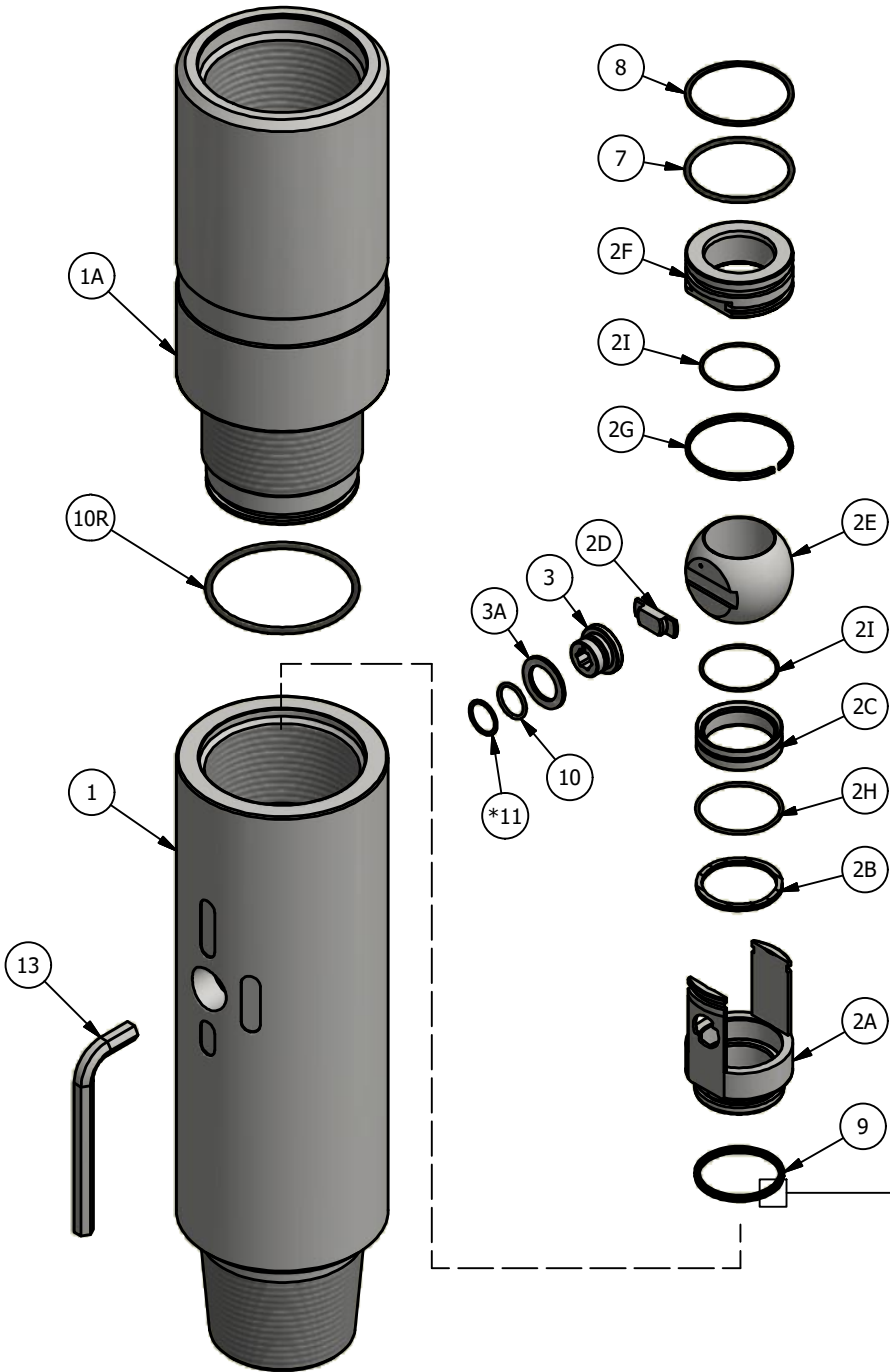

PARTS LIST		
ITEM	QTY	DESCRIPTION
1	1	LOWER BODY
1A	1	UPPER BODY
2	1	COMPLETE CANISTER ITEMS 2A-2I, 7, 8, 9
2A	1	CAGE
2B	1	SPRING
2C	1	LOWER SEAT
2D	1	STEM LINK
2E	1	BALL
2F	1	UPPER SEAT
2G	1	CAGE/SEAT FASTENER
2H	1	LOWER SEAT O-RING
2I	2	UPPER/LOWER SEAT TEFLON RING
3	1	STEM
3A	1	THRUST BEARING
7	1	UPPER SEAT O-RING
8	1	UPPER SEAT BACK-UP RING
9	1	CANISTER SEAL (LIP SEAL)
10	1	STEM O-RING
10R	1	BODY O-RING
*11	1	STEM BACK-UP RING
13	1	WRENCH
14		MAJOR SEAL KIT ITEMS 2H, 2I, 7, 8, 9, 10, 10R, *11
15		MAJOR PARTS KIT ITEMS 2, 3, 3A, 10, 10R, *11

**NOTE:** THIS ASSEMBLY IS APPLICABLE FOR THE FOLLOWING STANDARD CANISTER SIZES:

- 1) 1-75
- 2) 2-00
- 3) 2-25
- 4) 2-50
- 5) 2-75

\* THIS PART ONLY APPLIES TO 2-75 CANISTER

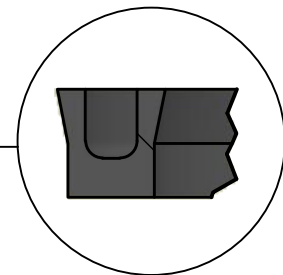

**M&M**<sup>INTL</sup>

**M&M International**  
P.O. Box 321  
Cade, LA 70519  
(337) 364-4145

DOCUMENT NUMBER: MM-GAD-2PKV-175-275  
REVISION NUMBER: 0  
DOCUMENT DATE: JUNE 10, 2019  
APPROVED BY: J. HINCAPIE

PROPERTY OF M&M INTERNATIONAL, INC. REPRODUCTION IN ANY FORM IS PROHIBITED WITHOUT WRITTEN, SIGNED AUTHORIZATION. MANUFACTURING FROM THIS PRINT EXPRESSES NO WARRANTY AS TO ACCURACY AND/OR WORKABILITY.