

CANISTER GUARD UPPER TOP DRIVE SAFETY VALVE

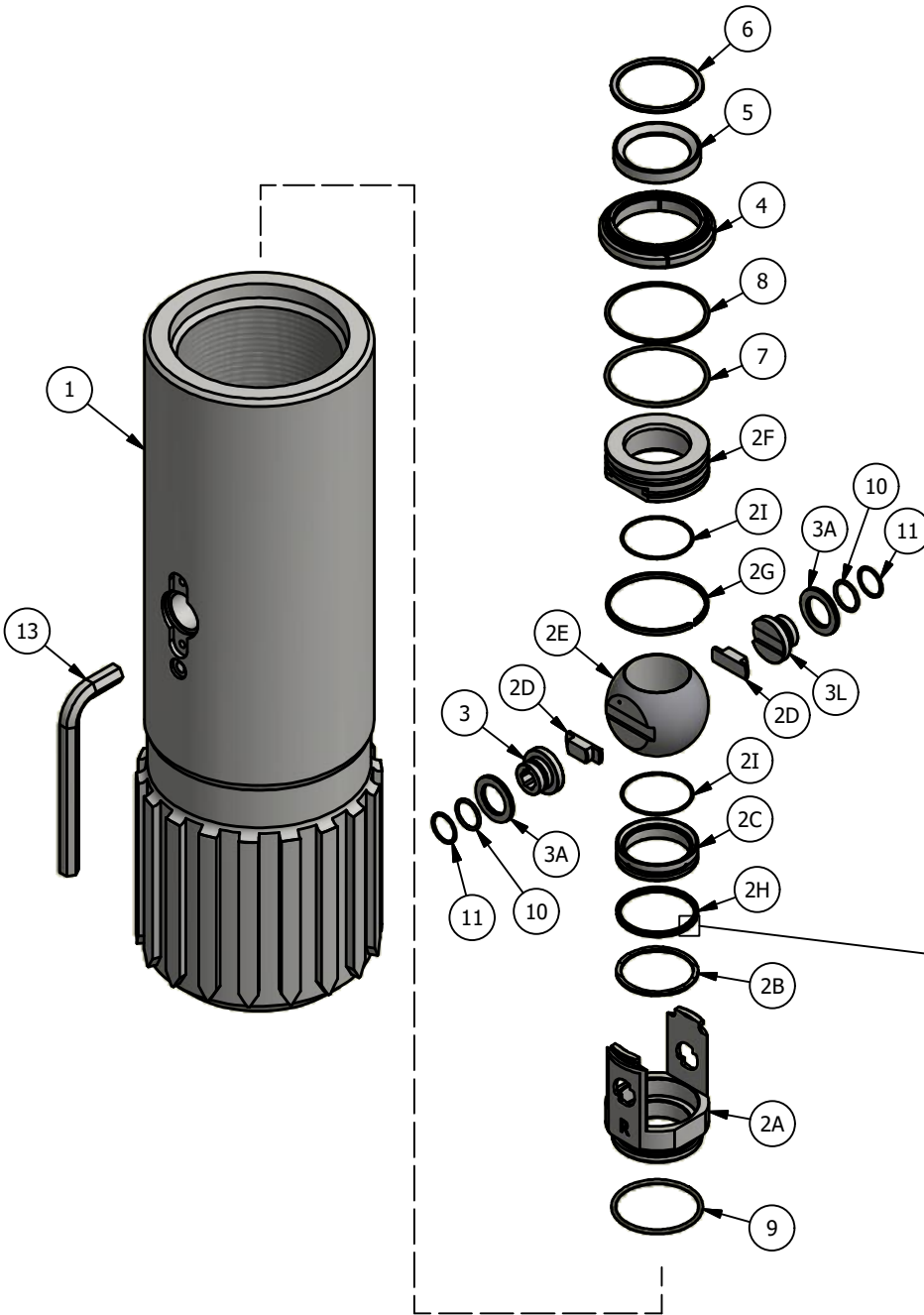

PARTS LIST		
ITEM	QTY	DESCRIPTION
1	1	VALVE BODY
2	1	COMPLETE CANISTER ITEMS 2A-2I, 7, 8, 9
2A	1	CAGE
2B	1	SPRING
2C	1	LOWER SEAT
2D	2	STEM LINK
2E	1	BALL
2F	1	UPPER SEAT
2G	1	CAGE/SEAT FASTENER
2H	1	LOWER SEAT SEAL (LIP SEAL)
2I	2	UPPER/LOWER SEAT TEFLON RING
3	1	STEM (RIGHT HAND)
3L	1	STEM (LEFT HAND)
3A	2	THRUST BEARING
4	1	LOCKING SEGMENTS
5	1	SUPPORT RING
6	1	SPIRAL RETAINER RING
7	1	UPPER SEAT O-RING
8	1	UPPER SEAT BACK-UP RING
9	1	CANISTER O-RING
10	2	STEM O-RING
11	2	STEM BACK-UP RING
13	1	WRENCH
14		MAJOR SEAL KIT ITEMS 2H, 2I, 7, 8, 9, 10, 11
15		MAJOR PARTS KIT ITEMS 2, 3, 3L, 3A, 10, 11

NOTE: THIS ASSEMBLY IS APPLICABLE FOR THE FOLLOWING STANDARD CANISTER SIZES:
1) 3-00
2) 3-06

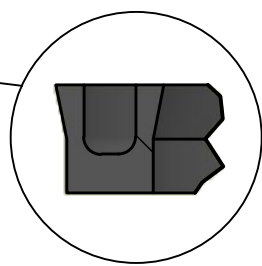

M&M INTL
M&M International
 P.O. Box 321
 Cade, LA 70519
 (337) 364-4145

DOCUMENT NUMBER: MM-GAD-UPTV-300-306
 REVISION NUMBER: 0
 DOCUMENT DATE: JUNE 10, 2019
 APPROVED BY: J. HINCAPIE

PROPERTY OF M&M INTERNATIONAL, INC. REPRODUCTION IN ANY FORM IS PROHIBITED WITHOUT WRITTEN, SIGNED AUTHORIZATION. MANUFACTURING FROM THIS PRINT EXPRESSES NO WARRANTY AS TO ACCURACY AND/OR WORKABILITY.